



National
Qualifications
2022 MODIFIED

X847/77/11

**Mathematics
Paper 1 (Non-calculator)**

FRIDAY, 6 MAY
9:00 AM – 10:00 AM



Total marks — 35

Attempt ALL questions.

You must NOT use a calculator.

To earn full marks you must show your working in your answers.

State the units for your answer where appropriate.

You will not earn marks for answers obtained by readings from scale drawings.

Write your answers clearly in the spaces provided in the answer booklet. The size of the space provided for an answer is not an indication of how much to write. You do not need to use all the space.

Additional space for answers is provided at the end of the answer booklet. If you use this space you must clearly identify the question number you are attempting.

Use **blue** or **black** ink.

Before leaving the examination room you must give your answer booklet to the Invigilator; if you do not, you may lose all the marks for this paper.



* X 8 4 7 7 7 1 1 *

FORMULAE LIST

Standard derivatives	
$f(x)$	$f'(x)$
$\sin^{-1} x$	$\frac{1}{\sqrt{1-x^2}}$
$\cos^{-1} x$	$-\frac{1}{\sqrt{1-x^2}}$
$\tan^{-1} x$	$\frac{1}{1+x^2}$
$\tan x$	$\sec^2 x$
$\cot x$	$-\operatorname{cosec}^2 x$
$\sec x$	$\sec x \tan x$
$\operatorname{cosec} x$	$-\operatorname{cosec} x \cot x$
$\ln x$	$\frac{1}{x}$
e^x	e^x

Standard integrals	
$f(x)$	$\int f(x) dx$
$\sec^2(ax)$	$\frac{1}{a} \tan(ax) + c$
$\frac{1}{\sqrt{a^2-x^2}}$	$\sin^{-1}\left(\frac{x}{a}\right) + c$
$\frac{1}{a^2+x^2}$	$\frac{1}{a} \tan^{-1}\left(\frac{x}{a}\right) + c$
$\frac{1}{x}$	$\ln x + c$
e^{ax}	$\frac{1}{a} e^{ax} + c$

Summations

(Arithmetic series)
$$S_n = \frac{1}{2}n[2a + (n-1)d]$$

(Geometric series)
$$S_n = \frac{a(1-r^n)}{1-r}, r \neq 1$$

$$\sum_{r=1}^n r = \frac{n(n+1)}{2}, \quad \sum_{r=1}^n r^2 = \frac{n(n+1)(2n+1)}{6}, \quad \sum_{r=1}^n r^3 = \frac{n^2(n+1)^2}{4}$$

Binomial theorem

$$(a+b)^n = \sum_{r=0}^n \binom{n}{r} a^{n-r} b^r \quad \text{where} \quad \binom{n}{r} = {}^n C_r = \frac{n!}{r!(n-r)!}$$

Maclaurin expansion

$$f(x) = f(0) + f'(0)x + \frac{f''(0)x^2}{2!} + \frac{f'''(0)x^3}{3!} + \frac{f^{iv}(0)x^4}{4!} + \dots$$

FORMULAE LIST (continued)

De Moivre's theorem

$$[r(\cos \theta + i \sin \theta)]^n = r^n (\cos n\theta + i \sin n\theta)$$

Vector product

$$\mathbf{a} \times \mathbf{b} = |\mathbf{a}||\mathbf{b}|\sin \theta \hat{\mathbf{n}}$$
$$= \begin{vmatrix} \mathbf{i} & \mathbf{j} & \mathbf{k} \\ a_1 & a_2 & a_3 \\ b_1 & b_2 & b_3 \end{vmatrix} = \mathbf{i} \begin{vmatrix} a_2 & a_3 \\ b_2 & b_3 \end{vmatrix} - \mathbf{j} \begin{vmatrix} a_1 & a_3 \\ b_1 & b_3 \end{vmatrix} + \mathbf{k} \begin{vmatrix} a_1 & a_2 \\ b_1 & b_2 \end{vmatrix}$$

Matrix transformation

Anti-clockwise rotation through an angle, θ , about the origin, $\begin{pmatrix} \cos \theta & -\sin \theta \\ \sin \theta & \cos \theta \end{pmatrix}$

[Turn over

Total marks — 35
Attempt ALL questions

1. (a) Given $y = \frac{1-3x}{x^2+4}$, find $\frac{dy}{dx}$. Simplify your answer. 3
- (b) Given $f(x) = \operatorname{cosec} 5x$, find $f'(x)$. 2
2. Use Gaussian elimination to solve the following system of equations:
- $$\begin{aligned}x - 2y + z &= 4 \\2x + y - 3z &= 3 \\x - 7y - 4z &= 9\end{aligned}$$
- 4
3. Given that $z_1 = 5 + 3i$ and $z_2 = 6 + 2i$, express $z_1 \bar{z}_2$ in the form $a + ib$ where a and b are real numbers. 2
4. A curve is defined by the equation $y^3 + 4y = 2xy + 1$.
- (a) Use implicit differentiation to find an expression for $\frac{dy}{dx}$. 3
- (b) Find the gradient of the tangent to the curve when $y = -1$. 1
- (c) Show that the curve has no stationary point. 2
5. (a) Find, and simplify, the Maclaurin expansion for e^{-4x} , up to and including the term in x^3 . 2
- (b) Hence find the first four terms of the Maclaurin expansion of $\frac{3+2x}{e^{4x}}$. 2

6. (a) Consider the statement:

For all odd numbers n , $n^2 + 4$ is prime.

Find a counterexample to show that the statement is false.

1

- (b) Prove directly that the difference between the cubes of any two consecutive integers is not divisible by 3.

3

7. (a) Use the substitution $u = y^2 + 1$, or otherwise, to find the exact value of

$$\int_0^5 \frac{4y}{\sqrt{y^2 + 1}} dy.$$

4

Student engineers are using a 3D printer to make a model.

Relative to a suitable set of axes, the cross-section of the model is **symmetrical about the y -axis** and is represented **in the first quadrant** by the curve with equation

$x = \frac{4y}{\sqrt{y^2 + 1}}$, $0 \leq y \leq 5$, as shown in the diagram.

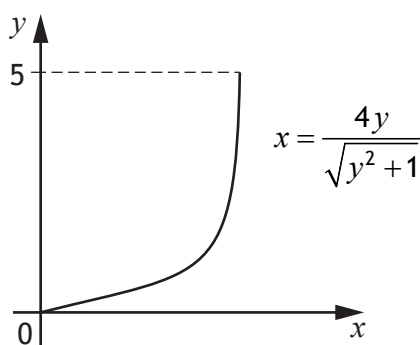

- (b) State the area of the cross-section.

1

- (c) Express $\frac{y^2}{y^2 + 1}$ in the form $a + \frac{b}{y^2 + 1}$ where a and b are real numbers.

1

The curve $x = \frac{4y}{\sqrt{y^2 + 1}}$, $0 \leq y \leq 5$, will be rotated through 2π radians about the y -axis to make the model.

- (d) Find the volume of the model.

4

[END OF QUESTION PAPER]



National
Qualifications
2022 MODIFIED

X847/77/12

**Mathematics
Paper 2**

FRIDAY, 6 MAY

10:30 AM – 12:30 PM

Total marks — 65

Attempt ALL questions.

You may use a calculator.

To earn full marks you must show your working in your answers.

State the units for your answer where appropriate.

You will not earn marks for answers obtained by readings from scale drawings.

Write your answers clearly in the spaces provided in the answer booklet. The size of the space provided for an answer is not an indication of how much to write. You do not need to use all the space.

Additional space for answers is provided at the end of the answer booklet. If you use this space you must clearly identify the question number you are attempting.

Use **blue** or **black** ink.

Before leaving the examination room you must give your answer booklet to the Invigilator; if you do not, you may lose all the marks for this paper.



* X 8 4 7 7 7 1 2 *

FORMULAE LIST

Standard derivatives	
$f(x)$	$f'(x)$
$\sin^{-1} x$	$\frac{1}{\sqrt{1-x^2}}$
$\cos^{-1} x$	$-\frac{1}{\sqrt{1-x^2}}$
$\tan^{-1} x$	$\frac{1}{1+x^2}$
$\tan x$	$\sec^2 x$
$\cot x$	$-\operatorname{cosec}^2 x$
$\sec x$	$\sec x \tan x$
$\operatorname{cosec} x$	$-\operatorname{cosec} x \cot x$
$\ln x$	$\frac{1}{x}$
e^x	e^x

Standard integrals	
$f(x)$	$\int f(x) dx$
$\sec^2(ax)$	$\frac{1}{a} \tan(ax) + c$
$\frac{1}{\sqrt{a^2-x^2}}$	$\sin^{-1}\left(\frac{x}{a}\right) + c$
$\frac{1}{a^2+x^2}$	$\frac{1}{a} \tan^{-1}\left(\frac{x}{a}\right) + c$
$\frac{1}{x}$	$\ln x + c$
e^{ax}	$\frac{1}{a} e^{ax} + c$

Summations

(Arithmetic series)
$$S_n = \frac{1}{2}n[2a + (n-1)d]$$

(Geometric series)
$$S_n = \frac{a(1-r^n)}{1-r}, r \neq 1$$

$$\sum_{r=1}^n r = \frac{n(n+1)}{2}, \quad \sum_{r=1}^n r^2 = \frac{n(n+1)(2n+1)}{6}, \quad \sum_{r=1}^n r^3 = \frac{n^2(n+1)^2}{4}$$

Binomial theorem

$$(a+b)^n = \sum_{r=0}^n \binom{n}{r} a^{n-r} b^r \quad \text{where} \quad \binom{n}{r} = {}^n C_r = \frac{n!}{r!(n-r)!}$$

Maclaurin expansion

$$f(x) = f(0) + f'(0)x + \frac{f''(0)x^2}{2!} + \frac{f'''(0)x^3}{3!} + \frac{f^{iv}(0)x^4}{4!} + \dots$$

FORMULAE LIST (continued)

De Moivre's theorem

$$[r(\cos \theta + i \sin \theta)]^n = r^n (\cos n\theta + i \sin n\theta)$$

Vector product

$$\mathbf{a} \times \mathbf{b} = |\mathbf{a}||\mathbf{b}|\sin \theta \hat{\mathbf{n}}$$
$$= \begin{vmatrix} \mathbf{i} & \mathbf{j} & \mathbf{k} \\ a_1 & a_2 & a_3 \\ b_1 & b_2 & b_3 \end{vmatrix} = \mathbf{i} \begin{vmatrix} a_2 & a_3 \\ b_2 & b_3 \end{vmatrix} - \mathbf{j} \begin{vmatrix} a_1 & a_3 \\ b_1 & b_3 \end{vmatrix} + \mathbf{k} \begin{vmatrix} a_1 & a_2 \\ b_1 & b_2 \end{vmatrix}$$

Matrix transformation

Anti-clockwise rotation through an angle, θ , about the origin, $\begin{pmatrix} \cos \theta & -\sin \theta \\ \sin \theta & \cos \theta \end{pmatrix}$

[Turn over

Total marks — 65
Attempt ALL questions

1. Express $\frac{3x^2 - 3x + 5}{x(x^2 + 5)}$ in partial fractions. 3

2. Find the exact value of $\int_0^3 \frac{4}{2x+1} dx$. 2

3. Use the Euclidean algorithm to find integers a and b such that
 $634a + 87b = 1$. 3

4. Use integration by parts to find $\int (x+2)(2x+7)^{\frac{1}{2}} dx$. 3

5. Matrix A is given by

$$A = \begin{pmatrix} 1 & 3 & 1 \\ 2 & k & 3 \\ k & 18 & -7 \end{pmatrix}, \text{ where } k \in \mathbb{R}.$$

Find the values of k so that the matrix A is singular. 3

6. The first three terms of a sequence are defined algebraically by

$$x+5, 3x+2, 5x-1, \text{ where } x \in \mathbb{N}.$$

(a) Show that these three terms form the start of an arithmetic sequence. 2

(b) Find a simplified expression for the 15th term of this sequence. 2

(c) Given that the sum of the first 20 terms of this sequence is 1130, find the value of x . 2

7. The complex number $z = 3 + i$ is a root of $z^2 - 6z + a = 0$, where a is a real number.

(a) State the second root of $z^2 - 6z + a = 0$. 1

(b) Hence, or otherwise, find the value of a . 2

The expression $z^2 - 6z + a$ is a factor of $z^3 - z^2 - 20z + b$, where b is a real number.

(c) Find the value of b . 1

8. (a) Differentiate $x \ln x - x$ with respect to x . 2

(b) Hence find the general solution of the differential equation

$$\frac{dy}{dx} + y \ln x = x^{-x}. \quad 4$$

9. The matrix A is given by $A = \begin{pmatrix} 3 & -2 \\ 0 & 1 \end{pmatrix}$.

Prove by induction that

$$A^n = \begin{pmatrix} 3^n & 1 - 3^n \\ 0 & 1 \end{pmatrix}, \quad \forall n \in \mathbb{N}. \quad 5$$

10. Solve the differential equation

$$\frac{d^2y}{dx^2} - 4 \frac{dy}{dx} + 4y = 9 \sin x + 13 \cos x$$

given that $y = 5$ and $\frac{dy}{dx} = 0$ when $x = 0$. 9

11. A curve defined parametrically has the following properties:

- $x = \tan^{-1} 2t$
- $\frac{dy}{dx} = 6t(1 + 4t^2)$
- $y = 5$ when $t = 1$.

Find y in terms of t . 4

12. Let $z = \cos \theta + i \sin \theta$.

- (a) Use de Moivre's theorem to state an expression for z^4 . 1
- (b) State and simplify the binomial expansion of $(\cos \theta + i \sin \theta)^4$. 3
- (c) Hence show that:
- (i) $\cos 4\theta = 8 \cos^4 \theta - 8 \cos^2 \theta + 1$. 2
- (ii) $\sin \theta \cot 4\theta$ can be written in terms of $\cos \theta$ only. 2

13. A security spotlight is situated 10 metres from a straight fence. The spotlight rotates at a constant speed and makes one full revolution every 12 seconds.

The situation at time t seconds is modelled in the diagram below, where:

- L is the position of the spotlight
- G is the point on the fence nearest to the spotlight
- P is the position where the light hits the fence
- θ is the angle between LG and LP
- x is the distance in metres from G to P.

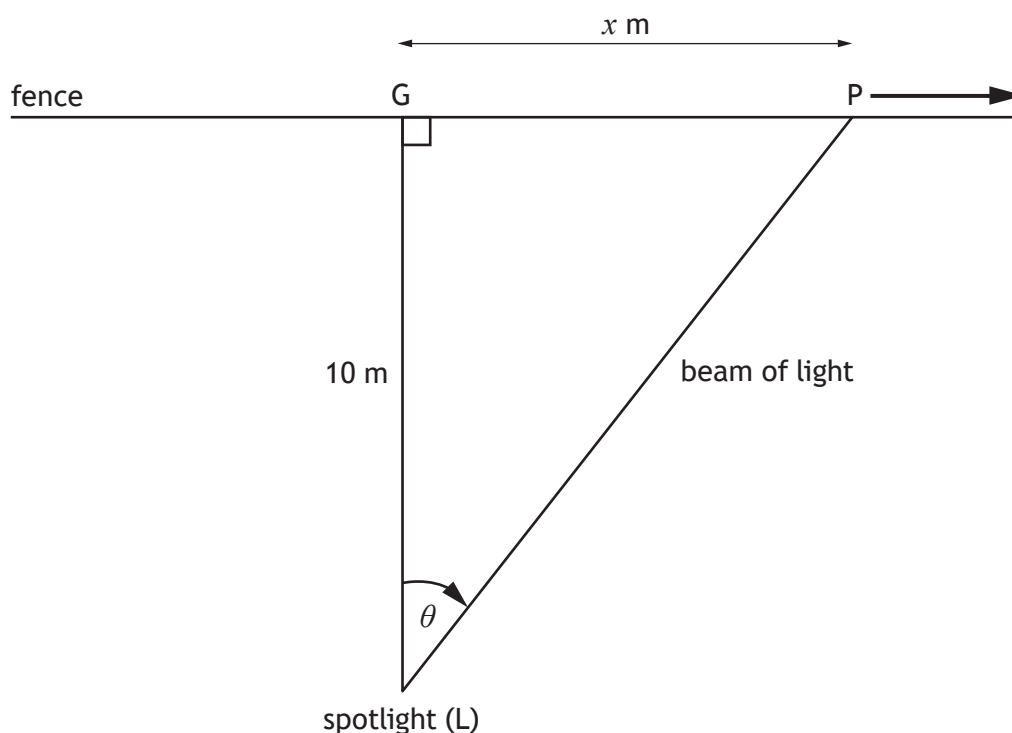

(a) Show that:

(i) $\frac{d\theta}{dt} = \frac{\pi}{6}$ radians per second 1

(ii) $\frac{dx}{dt} = \frac{5\pi}{3} \sec^2 \theta$ metres per second. 4

(b) Prove that $1 + \tan^2 \theta = \sec^2 \theta$. 1

(c) Hence, or otherwise, find the exact value of $\frac{dx}{dt}$ when P is 5 metres from G. 3

[END OF QUESTION PAPER]